

## Load Current in PSCAD

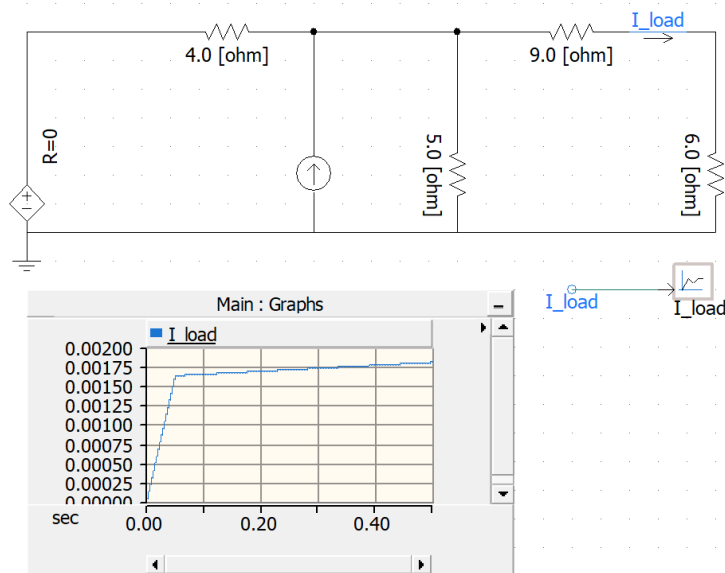

## Sine wave production

- Produce a sine wave  $5.5\sin(100t)$  through PSCAD

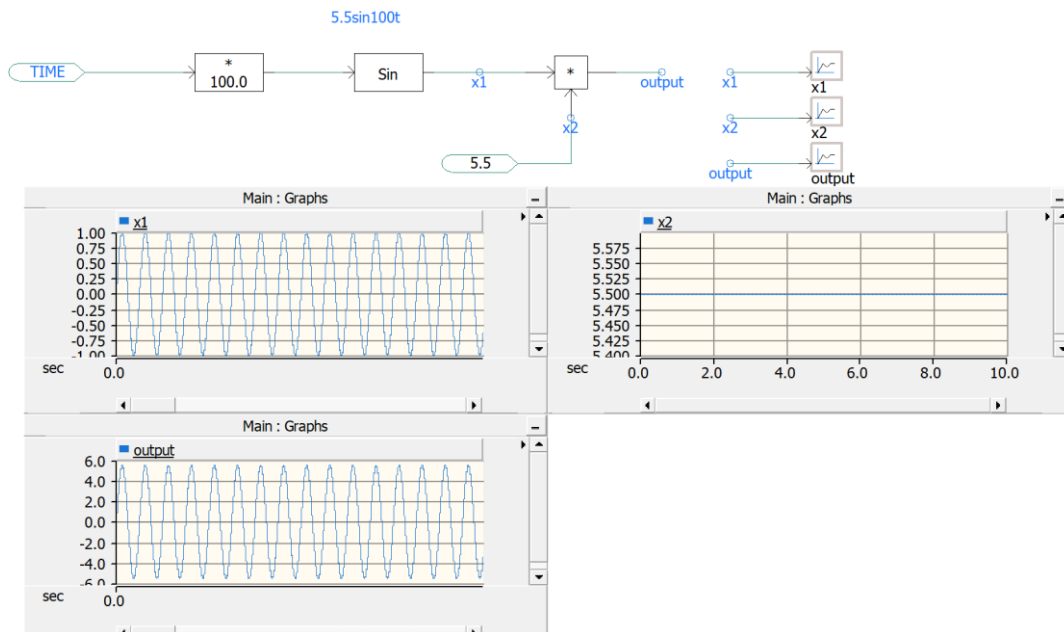

## 3 phase faults

- The three phase fault analysis circuit created on PSCAD is shown below:

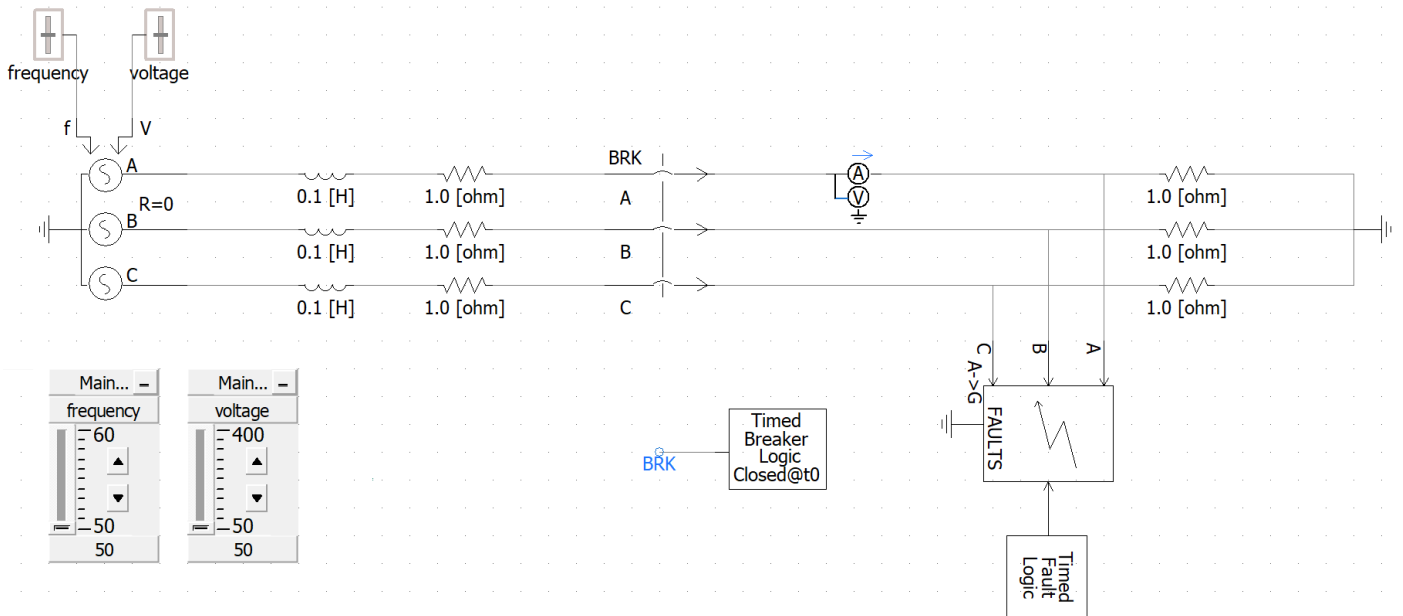

- Circuit explanation

- At the left, three phase adjustable sources (ABC) with frequency and voltage sliders (Grid side sources)
  - ◆  $V_A(t) = V\sin(\omega t)$ ,  $V_B(t) = V\sin(\omega t - 120^\circ)$ ,  $V_C(t) = V\sin(\omega t - 240^\circ)$
- And the series inductors and resistors create a realistic source impedance, they determine the fault current magnitude, X/R ratio and transient response.
- The Breaker and Timed Breaker Logic (switching): it can open and close all phases simultaneously, and the timed breaker logic decides when the breaker closes and opens.
- Fault block: creates all types of fault. Ex. A->G means a single phase to ground fault on phase A.
- Timed Fault Logic: it determines when the fault will happen

- Fault design:

- In Timed Fault Logic, the fault is set to happen at 5 seconds till 5.2 seconds
- And in Timed Breaker Logic, the breaker will be open at 5.1 seconds
- From above, the single phase fault A->G will exist between 5 to 5.1 seconds, and at 5.2 seconds the fault is removed.
- Breaker clearing time: 0.1 seconds after fault is triggered

- The voltage and current simulation results are shown below:

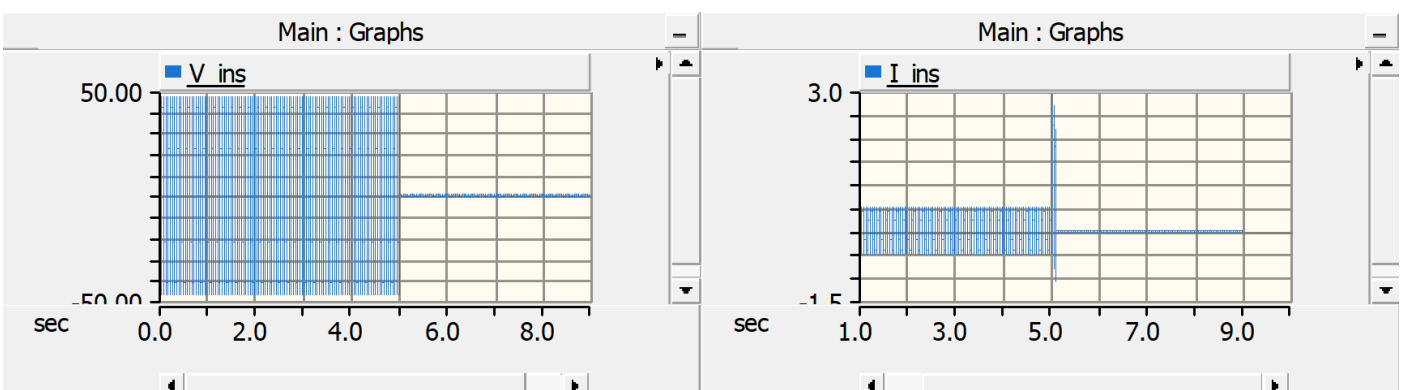

- As shown from the simulation, the system is operating normally before 5 seconds, the voltage

drops and current spikes when the fault hits. And the current drops to zero when the breaker opens and it stays flat after the fault is cleared due to the isolated line

### One line diagram in PSCAD

- Configure transmission line in PSCAD based on real world data:

Definition Canvas (TLine\_1)

Segment Name: TLine\_1

Steady State Frequency: 60.0 [Hz]

Length of Line: 100.0 [km]

Number of Conductors: 3

Bergeron Model Options

Travel Time Interpolation: On

Reflectionless Line (ie Infinite Length): No

Manual Entry of Y,Z

+ve Sequence R: 0 [ohm/m]

+ve Sequence Travel Time: 3.333e-9 [s/m]

+ve Sequence Surge Impedance: 30 [ohm]

- Looking into Bewley's Lattice diagram from transmission line (failed)

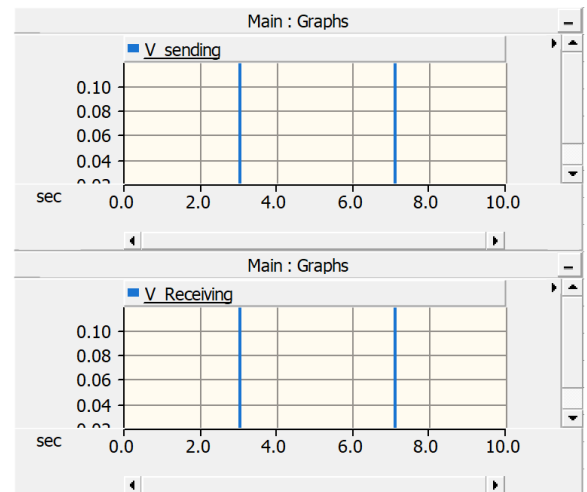
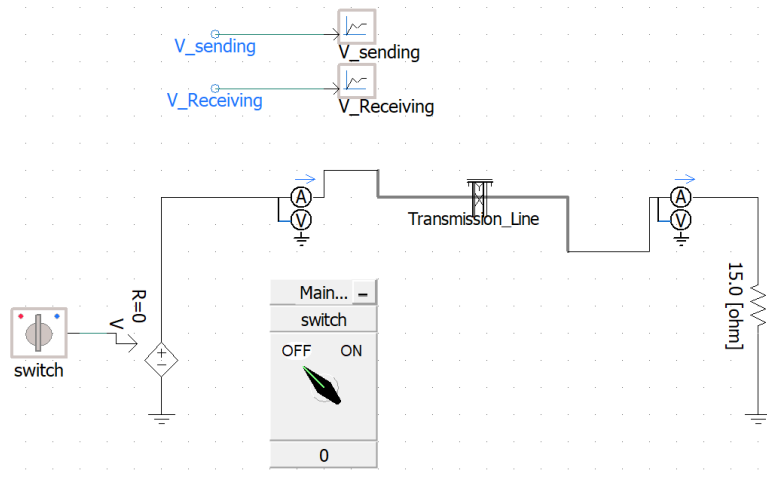

### Transmission line configuration based on real world datasheet

- The transmission line data sheet is shown below

Span #	GANTRY - TOWER #1	TOWER #1 - TOWER #2	TOWER #2 - TOWER #3	TOWER #3 - TOWER #4	TOWER #4 - TOWER #5
Span length [Meter] - 350					
CONDUCTOR SAG - 9081mm					
EW SAG - 9081mm					
Average Sag [Meter] - 9081mm					
Tower Number # (From gantry end) - 402	Tower #1	Tower #2	Tower #3	Tower #4	Tower #5
Type of Tower (Tension / Suspension) TENSION (B+3 D/C)					
Tower footing resistance [Ohm] - 15.8 Ω					
Average soil resistivity [Ohm-m] 3.18 Ω/m					
Tower dimensions based on tower scheme	Tower Type (A,B,C,D)				
	a [Meter]	11.60			
	b [Meter]	20.0			
	c [Meter]	5.25			
	d [Meter]	5.10			
	e [Meter]	7.925			
	f [Meter]	4.575			
	g [Meter]	4.50			
	h [Meter]	5.15			
	i [Meter]	38.50			
	j [Meter]	-			
k [Meter]	-				
l [Meter]	-				
m [Meter]	-				

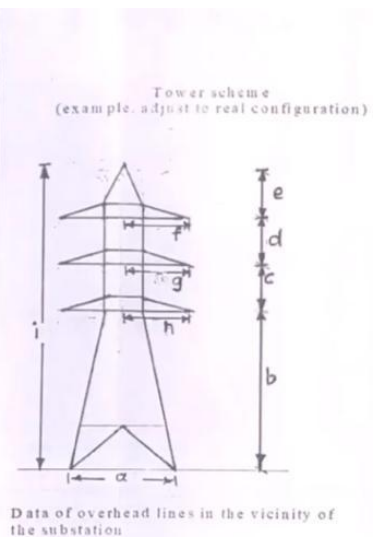

String insulator	Insulator type: ANTI FOG Number of disc in string: 16 Length of string [mm]: 2300mm Length of arcing gap [mm]: 240mm
Conductor	Name: 0.4 DEER Overall diameter [mm]: 28.62 DC resistance at 20° C [Ohm/km]: 3.626 Number of strands: 37 Strand diameter [mm]: 4.2 Number of conductor in bundle: Spacing between conductors in bundle[m] SINGLE Number of earth wires: 1
Earth wire/ shield wire	Type (OPGW or steel wire): OP6W DC resistance at 20° C [Ohm/km]: 3

- The data requires: conductor data, conductor coordinates, ground wire data, ground wire coordinates, and phase/node connection information

Definition Canvas (TLine_1)
Segment Name: TL_402
Steady State Frequency: 50.0 [Hz]
Length of Line: 350 [m]
Number of Conductors: 7

Frequency Dependent (Phase) Model Options
Travel Time Interpolation: On
Curve Fitting Starting Frequency: 0.5
Curve Fitting End Frequency: 1.0E6
Total Number of Frequency Increments: 100
Maximum Order of Fitting for Yc: 20
Maximum Fitting Error for Yc: 0.2
Max. Order per Delay Grp. for Prop. Func.: 20
Maximum Fitting Error for Prop. Func.: 0.2
DC Correction: Disabled
Passivity Checking: Disabled

Additional Options
Output File DisplaySettings:
Frequency for Calculation: 50.0 [Hz]
Display Zero Tolerance: 1.0E-19
Rated System Voltage (L-L, RMS): 230.0 [kV]
Rated System MVA: 100.0 [MVA]
Miscellaneous:
Create PI-Section Component?: No

Tower: 3H5  
Tower Centre 0.0 [m]  
Conductors: 0.4DEER  
Ground\_Wires: OP6W

Circuit #	Cond. #	Connection Phasing #	X (from tower centre) [m]	Y (at tower) [m]	GW. #	Connection Phasing #	X (from tower centre) [m]	Y (at tower) [m]
	1	2	4.575 [m]	30.35 [m]	1	1	0 [m]	38.5 [m]
	2	3	4.5 [m]	25.25 [m]				
	3	4	5.15 [m]	20 [m]				
	4	5	-4.575 [m]	30.35 [m]				
	5	6	-4.5 [m]	25.25 [m]				
	6	7	-5.15 [m]	20 [m]				

Resistivity: 3.18
Aerial: Analytical Approximation (Deri-Semlyen)
Underground: Direct Numerical Integration
Mutual: Analytical Approximation (Lucca)

## Reactance and Resistance X/R Ratio impact on three phase fault

When there is a fault, the fault current has two parts: AC part (the normal sinusoidal short-circuit current) and DC offset (a big jump at the start of the fault). And the X/R ratio controls only the DC.

- One line drawing description: three phase voltage source with a three phase to ground fault at the downstream terminal.

- Voltage = 220kV
- Frequency = 50hz
- Fault current = 25kA
- X/R = 5
- $MVA = \sqrt{3}VI = \sqrt{3} * 220 * 25 = 9526.279$

- $Z = \frac{(kV)^2}{MVA} = \frac{220^2}{9526.279} = 5.08\Omega$

- $R = \frac{Z}{\sqrt{1+(\frac{X}{R})^2}} = \frac{5.08}{\sqrt{1+5^2}} = 0.996\Omega$

- $X = \frac{5}{0.996} = 4.98\Omega$

- $$L = \frac{X}{2\pi f} = 0.0159H$$

- Inserting relevant parameters for a single line diagram

- Three phase power source

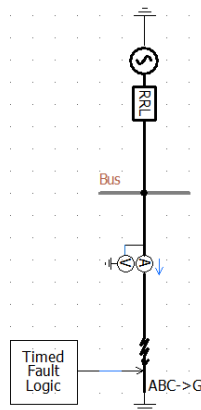

- Evaluate the instantaneous current and RMS

- Check the performance of the waveforms based on the change of the Z ratio
  - The below waveforms of instantaneous and RMS current with 5 X/R ratio

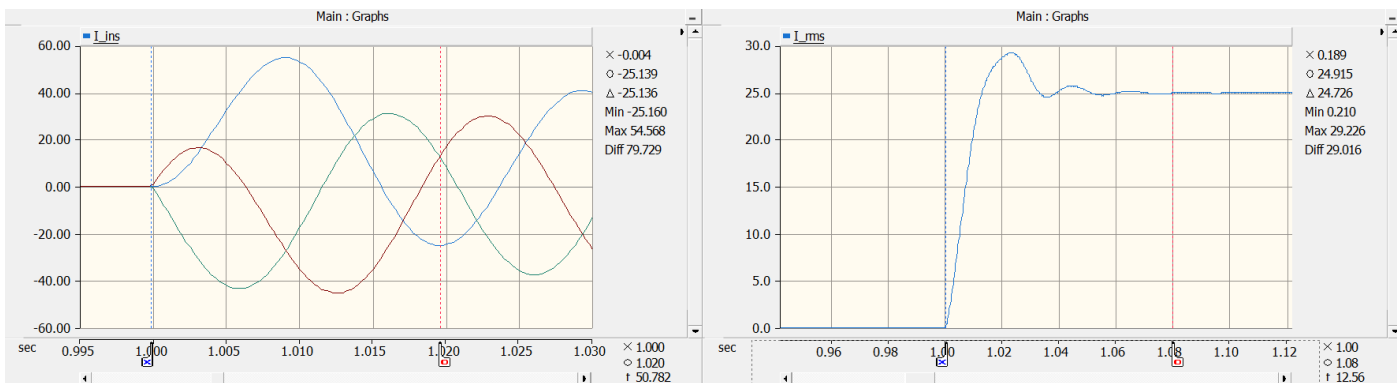

- The below waveforms of instantaneous and RMS current with 20 X/R ratio

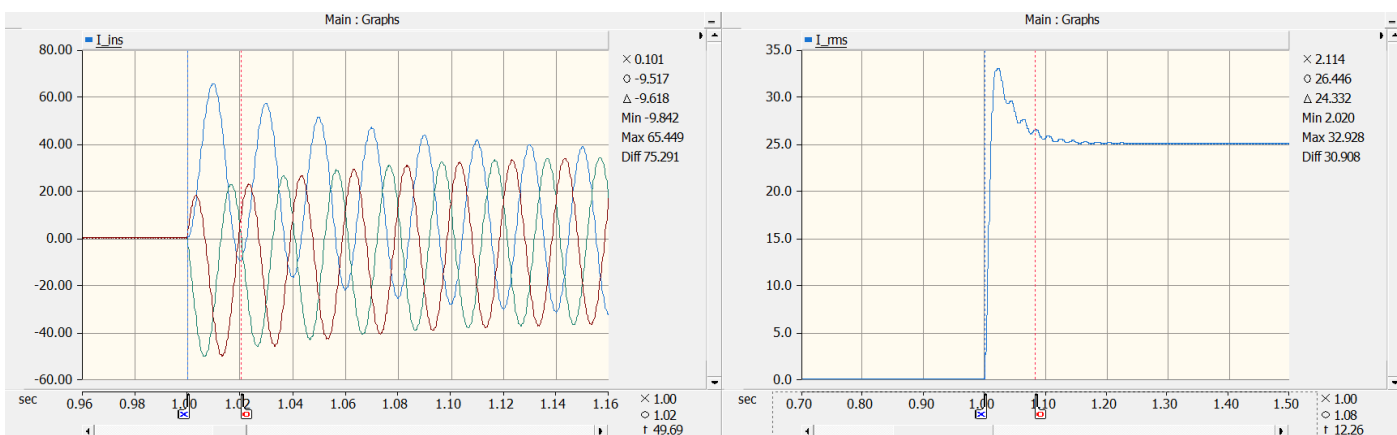

- From the results shown above:

- For instantaneous current waveforms: When X/R ratio is 5: the waveform has the DC offset at the very start, and it settles into a normal condition very fast. And the one with 20 X/R ratio is heavily shifted up and down at the beginning with much stronger DC offset, and it takes longer time to settle back to normal condition. It gives conclusion: higher X/R rate gives the waveform more DC offset with lower decay.
  - For RMS current waveforms: the one with 20 X/R ratio has higher overshoot.
  - Above, the bigger X/R ratio makes the fault current has bigger impact on power system.

## Coaxial cable design

- Coaxial cable configuration based on industrial data sheet and standard (IEC 62067)
  - The below graph is a configuration example of an underground power cable.
  - The below is a C1|I1|C2|I2|C3|I3 example. Stranded conductor is C1, insulation is I1, metallic sheath is C2, bedding is I2, armouring is C3, serving is I3

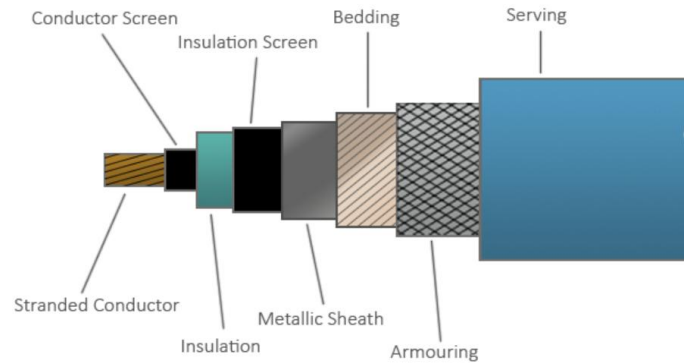

- The datasheet of the coaxial cable is shown below:

Cable Type : Single Core x 630 mm <sup>2</sup> 127/220 KV		ANNEXURE-A	
		GENERAL TECHNICAL PARTICULARS FOR 220 KV CABLE	
S.No	Particulars	Technical Details Data (220 kV, 1C x 630 sqmm)	
C	Metallic sheath		
(I)	Material	Annular Corrugated <b>Aluminium Sheath-Seam</b> welded	
(II)	Min.Thickness	<b>2.70 mm</b> (Nominal thickness of Aluminium Corrugation)	
(III)	Short Circuit Current Withstand Metallic Annular Aluminium Sheath	40 kamps for 3 seconds (Calculation enclosed)	
(IV)	Anticorrosion layer over the Aluminium Corrugation	Bitumin layer followed by bituminised cotton tape	
9	OUTER SHEATH		
(I)	Material	<b>Extruded Black HDPE</b> ST-7 , Antirodent & Antitermite	
(II)	Min. Thickness of outer sheath	<b>3.0 mm (minimum) / 4.0 mm (nominal)</b>	
10	Conducting layer over outer sheath	Extruded Semiconducting layer (0.30 mm Nominal)	
11	Approx. overall diameter of cable	114.0 +/- 3.0 mm	
	Embossing on Outer sheath at every one meter	KEI 127/220KV 1C x 630 SQMM Year of Mfg. MSETCL	
	Sequential length marking	Shall be provided at every one meter by Printing	
12	Approx. weight per meter of cable	Approx. 15.0 kg/m	
13	Recommended minimum installation radius	20 D (Where D is the overall diameter of the cable )	
14	Maximum D.C. Resistance of conductor at 90 Deg C	0.0361 Ohm/Km	

GENERAL TECHNICAL PARTICULARS FOR 220 KV CABLE		
S.No	Particulars	Technical Details Data (220 kV, 1C x 630 sqmm)
	Cable	Single Core, <b>Copper Conductor</b> XLPE Cable
1	Applicable standard	Generally conforming to IEC 62067
2	System voltage & frequency	220 ± 10%, 50 Hz ± 3%
3	Rated & Highest system voltage	245 kV
4	Suitable for earthed system	Yes
5	CONDUCTOR	
(I)	Material	Annealed Plain Copper
(II)	Nominal cross sectional area	630 sq.mm
(III)	Construction of conductor/flexibility class	Class-2
(IV)	Water tightness of conductor	Shall be achieved by providing the non conducting water Swellable tape at each layer of stranding except the final layer.
(V)	Semiconducting tape over the final layer of conductor	0.10 mm (Nominal)
(VI)	Max. DC Resistance at 20 Deg C	0.0283 Ohm/Km
(VII)	Max. AC Resistance at 90 Deg C	0.0390 Ohm/Km
(VIII)	Shape and formation	Stranded compacted Circular
(IX)	Approx. overall diameter of conductor	<b>30.2 mm +/- 0.6 mm</b>
6	CONDUCTOR SCREENING	
(I)	Material & type	Extruded semi conducting compound
(II)	Grade	as per IEC 62067
(III)	Thickness min	<b>1.0 mm</b>
(IV)	Resistivity of semi-conducting screen	1000 ohm-m
7	INSULATION	
(I)	Material	Cross Linked Polyethylene <b>XLPE</b>
(II)	Special super clean grade	as per IEC 62067
(III)	Nominal thickness of insulation	<b>23.0 mm (nominal)</b>
(IV)	Dielectric power factor at rated voltage	0.001
8	INSULATION SCREENING	
A	Non-metallic part (extruded)	
(I)	Material	Extruded semiconducting compound
(II)	Grade	as per IEC 62067
(III)	Min. thickness	<b>1.0 mm</b>
(IV)	Resistivity of semiconducting screen	500 Ohm-m
B	Non- metallic part (taped) longitudinal water barrier over insulation screen	
(I)	Material	Water swellable semi conducting Tape ( non woven ) & Water swellable semi conducting foam tapes

- The coaxial cable configuration on PSCAD based on the above information is shown below:

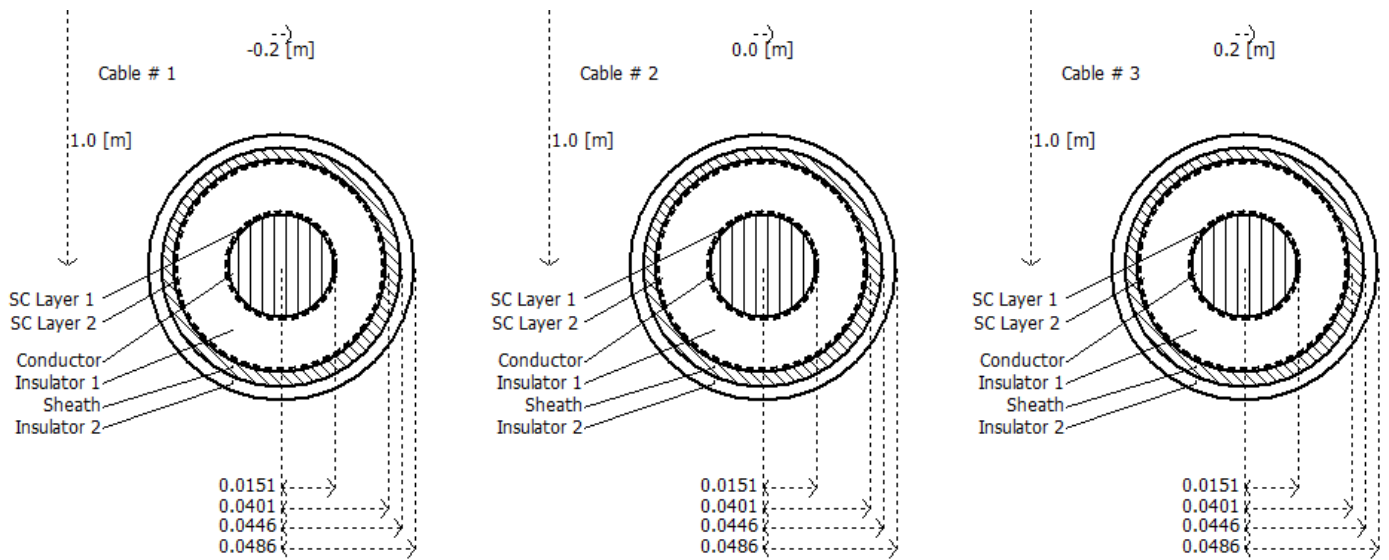

- Also the electrical properties (permeability, resistivity) of the cable are determined based on the standard IEC 60028

### Inrush Current

- Analysis is based on a simple example with a voltage source, a circuit breaker and a downstream transformer. The one-line drawing in PSCAD is shown below:

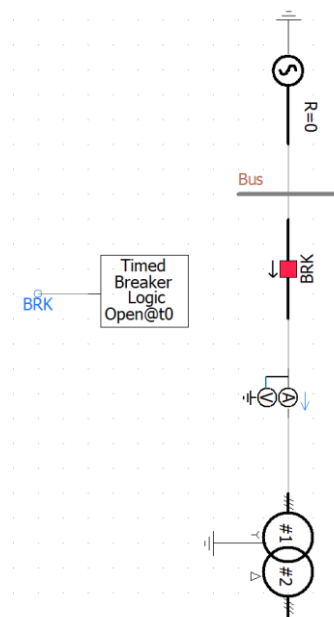

- And the multimeter is used to find the instantaneous current and the inrush current. Below is an example of the inrush current.

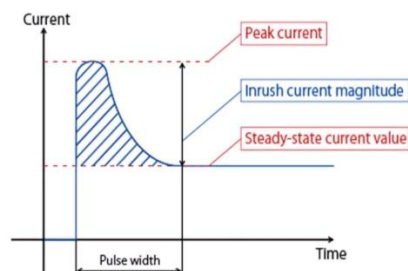

- The transformer configuration is constructed based on the below datasheet

## Technical Specification

100 MVA power transformer specification and data sheet

Delivered to	China		
Year	2014		
Model	S-100 MVA-220/35KV		
Type	Oil Immersed Power Transformer		
Standard	IEC60076		
Rated Power	100 MVA		
Frequency	50 HZ	Impedance	13%
Phase	Three	Tap Changer	OLTC
Cooling Type	ONAN	Tapping Range	±8*1.25%
Primary Voltage	220 KV	No Load Loss	61KW
Secondary Voltage	35 KV	On Load Loss	274KW
Winding Material	Copper	Accessories	Standard Configuration
Vector Group	DNy5	Remarks	N/A

- Eddy current losses (no load loss per unit) calculation:  $(\text{rated power} \times 1000) / (\text{no load loss} \times 10^6)$
- Copper losses (On load loss per unit) calculation:  $(\text{rated power} \times 1000) / (\text{on load loss} \times 10^6)$
- The configuration of the transformer on PSCAD is shown below:

Transformer Name	
3 Phase Transformer MVA	<b>100 [MVA]</b>
Base operation frequency	<b>50.0 [Hz]</b>
Winding #1 Type	<b>Delta</b>
Winding #2 Type	<b>Y</b>
Delta Lags or Leads Y	Lags
Positive sequence leakage reactance	<b>0.13 [pu]</b>
Ideal Transformer Model	<b>Yes</b>
Eddy current losses	<b>0.001639344 [pu]</b>
Copper losses	<b>0.000364964 [pu]</b>
Tap changer on winding	None
Graphics Display	Single line (circles)
Display Details?	No

## Transient Recovery Voltage (TRV)

TRV is the voltage that appears across the breaker terminals right after it interrupts a fault. When a fault happened, the circuit breaker opens, one side is connected to the source, and another side is connected to the faulted side. And **TRV is the voltage difference between the circuit breaker gap.**

- Power system one line drawing description:
  - RRL voltage source follows a Y-to-Y transformer, a circuit breaker with a transient recovery voltage connects the secondary side of the transformer, and a three phase to ground fault is ta the end of the power system.

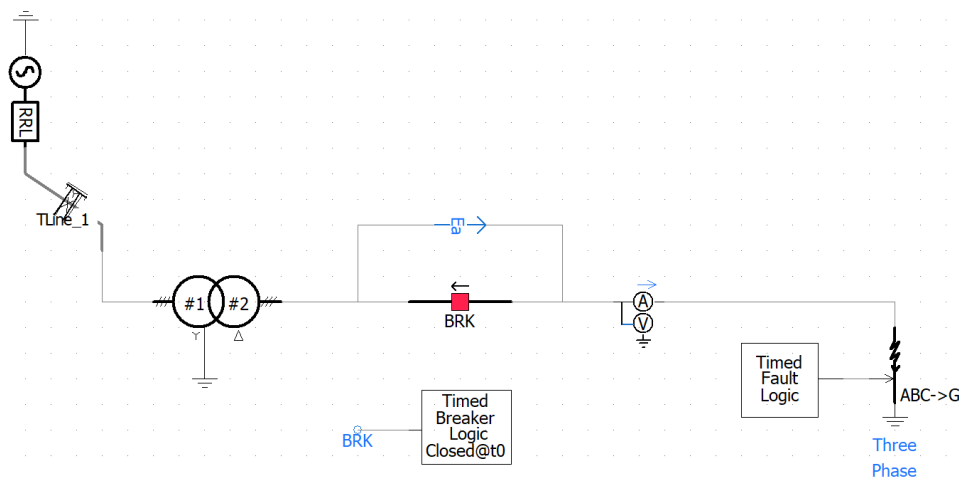

- The below is the transformer configuration. It's voltage ratio between primary and secondary sides is: 400kV : 132kV

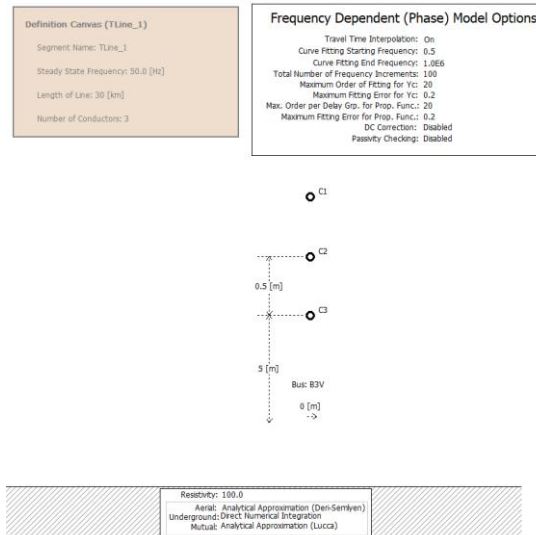

- Circuit setting:
  - ◆ Timed fault logic: fault is applied at 1 second
  - ◆ Timed circuit breaker logic: circuit breaker open at 1.1 seconds.
- The simulation result is shown below

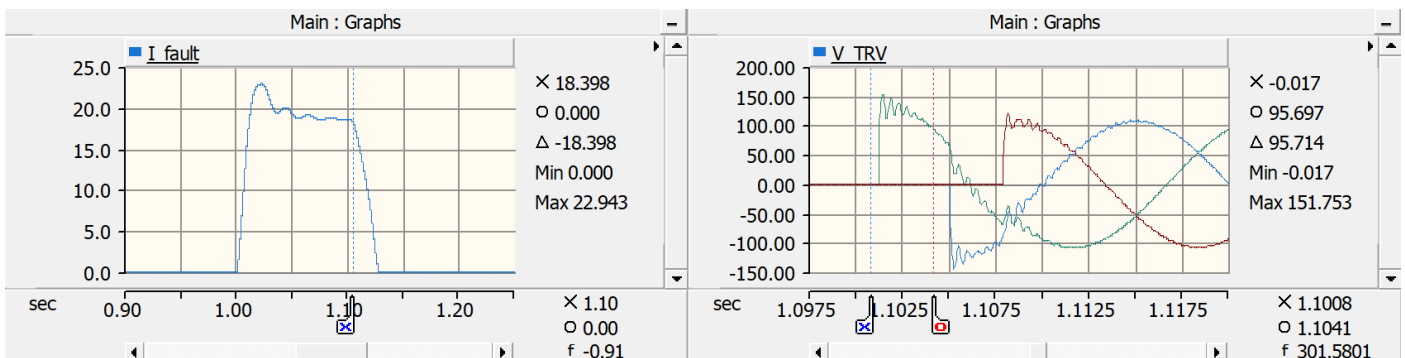

- ◆ From the above result:
  - At 1 second, the fault current appears, and the RMS fault current is around 18kA.
  - Circuit breaker opens at 1.1 seconds and the fault current starts dropping to zero
  - When the circuit breaker opens, it creates the voltage difference that generates Transient Recovery Voltage. At this moment, current goes to zero and TRV jumps up and oscillates.
- Identify the limits based on the standards (Ex. British Standards Institution)

**Table 26 – Standard values of prospective transient recovery voltage – Rated voltages of 100 kV and above**

Rated voltage	Test-duty	First-pole-to-clear factor	Amplitude factor	First reference voltage	Time	TRV peak value	Time	Time delay	Voltage	Time	Rate-of-rise
$U_r$		$k_{pp}$	$k_{af}$	$u_1$	$t_1$	$u_c$	$t_2$ or $t_3$	$t_d$	$u_{\text{C}}$	$t_{\text{C}}$	$u_1/t_1$ $u_c/t_3$
kV		p.u.	p.u.	kV	$\mu\text{s}$	kV	$\mu\text{s}$	$\mu\text{s}$	kV	$\mu\text{s}$	kV/ $\mu\text{s}$
100	T100	1,3	1,40	80	40	149	160	2 (11)	40	22 (31)	2
	T60	1,3	1,50	80	27	159	162	2-8	40	15-21	3
	T30	1,3	1,54	-	-	163	33	5	54	16	5
	T10	1,5	0,9 x 1,7	-	-	187	27	4	62	13	7
	OP1-OP2	2	1,25	122	80	204	160-320	2-8	61	42-48	1,54
123	T100	1,3	1,40	98	49	183	196	2 (14)	49	26 (38)	2
	T60	1,3	1,50	98	33	196	198	2-10	49	18-26	3
	T30	1,3	1,54	-	-	201	40	6	67	19	5
	T10	1,5	0,9 x 1,7	-	-	230	33	5	77	16	7
	OP1-OP2	2	1,25	151	98	251	196-392	2-10	75	51-59	1,54
145	T100	1,3	1,40	115	58	215	232	2 (16)	58	31 (45)	2
	T60	1,3	1,50	115	38	231	228	2-12	58	21-31	3
	T30	1,3	1,54	-	-	237	47	7	79	23	5
	T10	1,5	0,9 x 1,7	-	-	272	39	6	91	19	7
	OP1-OP2	2	1,25	178	116	296	232-464	2-12	89	60-70	1,54

- ◆ **1<sup>st</sup> step:** From the standard limits, the first thing should be checked is rated voltage (Circuit breaker voltage). The circuit breaker voltage is same as the voltage 132 kV of the secondary winding of the transformer.
  - The higher rated voltage 145kV is selected as the reference rated voltage in the standard.
- ◆ **2<sup>nd</sup> step:** check the RMS fault current, from the result shown previously, the rms fault current is 18.3 kA
- ◆ **3<sup>rd</sup> step:** confirm the rated circuit breaker current from the electrical drawing 40kA
- ◆ **4<sup>th</sup> step:** calculate the test-duty (stress test sequence the circuit breaker must pass to prove it can safely interrupt faults under real-world condition)
  - Test Duty =  $100 \times (\text{RMS current} / \text{circuit breaker current}) = 46\%$ . So the T60 is chosen
- ◆ **5<sup>th</sup> step:** check TRV, from the result, the maximum TRV is 151kV that is within the TRV limit 231kV under the standard.
- ◆ **6<sup>th</sup> step:** check the rate of rise of the TRV,  $1.1014 - 1.1012 = 0.0002$ . As the standard is using microseconds unit, so the rate of rise is  $\text{TRV} / (0.0002 \times 10^6) = 0.7$  that is under the limit of 3 in the standard.

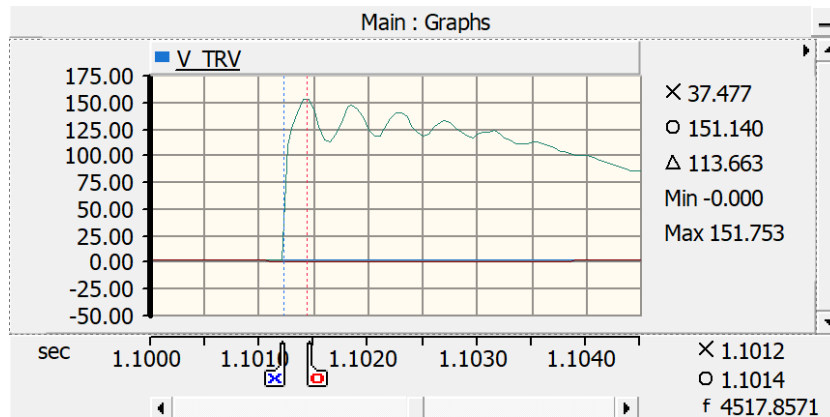

## Harmonic Analysis

- Harmonic definition: harmonics are the faster (frequency) copies of the main sine wave, the distorted waveform is generated when fundamental component and the harmonics are added together. **Adding fast harmonics makes the shape loop sharper (less smooth)**
  - For the below example, the 3<sup>rd</sup> and 5<sup>th</sup> harmonics turn the smooth sine wave fundamental component into a distorted square waveform

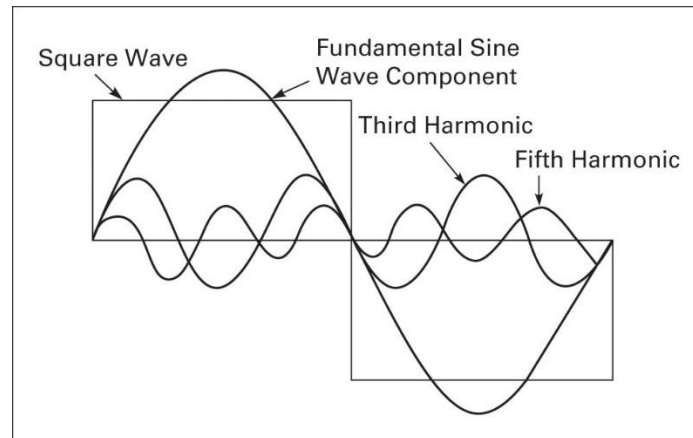

- Harmonic analysis example in PSCAD
  - The one line drawing is shown below:

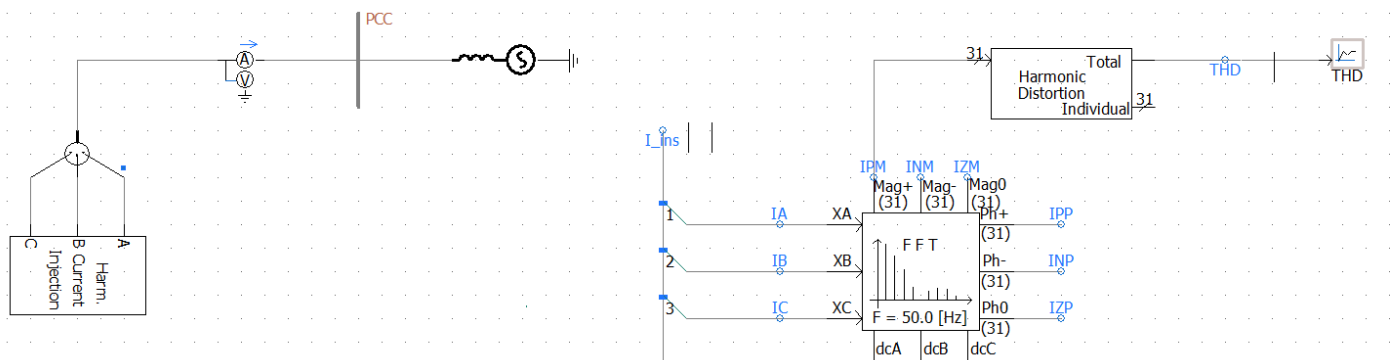

- ◆ The left one line drawing is shown the harmonic generator injects harmonics into the voltage source
- ◆ And the right one line drawing shows the FFT block that turns the distorted waveform into harmonic components such as the magnitude of each harmonic, phase of each harmonic, DC component, fundamental component, and etc. The THD (Total Harmonic Distortion) tells how bad the harmonics is

- The harmonics generator is set 50hz and 1000hz as the minimum and maximum frequencies. And the frequency increment is 50hz, which means there are 20 harmonics totally
- The harmonics number in the FFT block and THD should also be adjusted to the number higher than 20.
- The result is shown below:

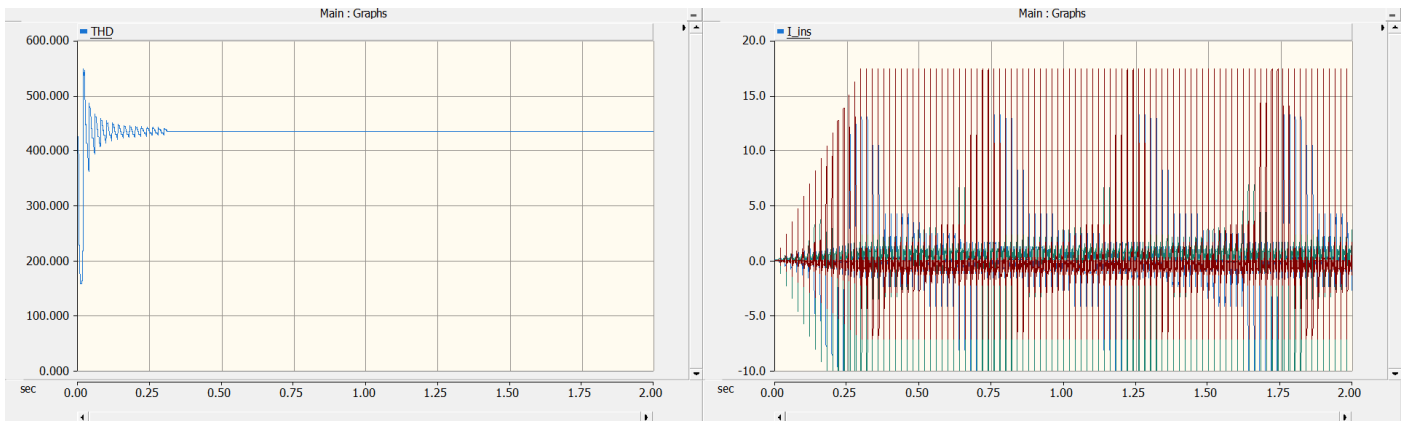

From the left THD result: it shows the magnitude of the positive-sequence harmonics. The initial big spike and the THD signal settles around 400% indicate the injected instantaneous current signal is extremely distorted with harmonics dominating the waveform. And the stable signal indicate the harmonics injection is steady and time unvaried.